

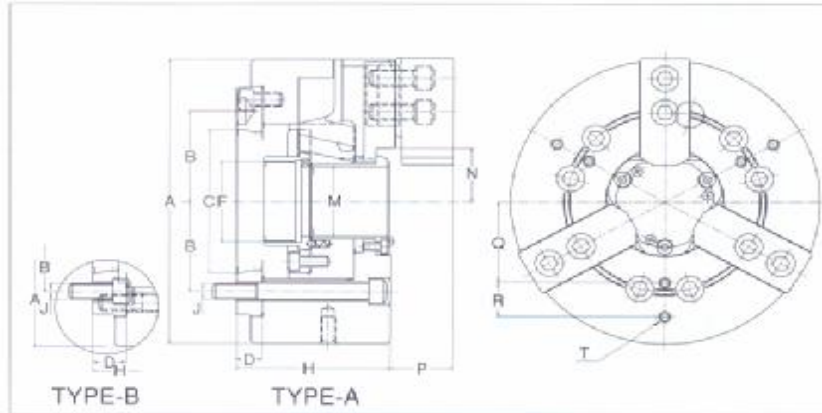

Big Bore Power Chuck Wedge Type



This is a Wedge Style Power Chuck that will provide the workpiece tolerance you demand for your turning center.



1.5 x 60 Serrations
Large Thru-hole
Direct Mount
Hi-Speed

Specification/Model	KCA6-8-66B	KCA8-10-80B	KCA8-12-93B	
Thru-hole	2.60	3.15	3.66	
Stroke of Jaws (on dia.)	0.30	0.35	0.35	
Stroke of Piston	0.67	0.78	0.78	
Chucking Diameter				
	Max	7.62	9.00	10.80
	Min	1.42	1.28	1.69
Gripping Force	lbs. 17,600	24,200	30,850	
Max Draw Pull	lbs. 6,830	9,580	13,450	
Max RPM	4,400	4,000	3,000	
Weight	lbs. 56	86	143	

Size/Model	KCA6-8-66B	KCA8-10-80B	KCA8-12-93B	
A	8.46	10	12	
B	2.62	3.37	3.37	
C	A6	A8	A8	
D	0.88	1.06	1.06	
F	M72xP1.5	M90xP2.0	M103xP2.0	
H	4.21	4.92	4.92	
J	6-M12	6-M16	6-M16	
M	2.60	3.15	3.66	
N				
	Max	1.83	2.14	2.56
	Min	1.68	1.96	2.38
P	1.65	1.73	2.12	
Q	2.36	3.15	3.34	
R	0.98	1.18	1.77	
T	6-M8deep15	6-M12deep18	6-M12deep18	