



Hydraulic / Pneumatic Stationary Power Chuck – Also Available with a Thru-Hole

Made In USA



- Low Profile Design perfect for CNC machining centers, standard mills and grinders
- Guaranteed 0.001" TIR repeatability on duplicate parts
- Can be used with air or hydraulic power (interchangeably)
- 6 & 8" 2 or 3-jaw models Tongue & Cross Key only
- 10 – 24" 2/3-Jaw Combination 1.5 x 60 °, Square Serrated, Tongue & Groove, 1/16 x 90 degree
- Sealed Face design to protect internal parts from abrasion
- Available in 2-jaw, 2/3-jaw combo and NC thru-hole styles
- Made in USA

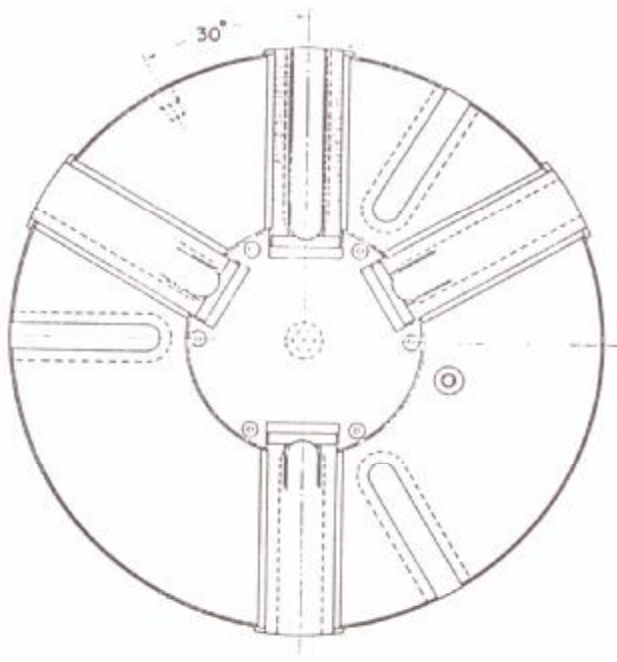

Chuck Size	Part Number	B-1	B-3	B-2	Jaw Travel	Max Drawbar Force (lbs)	Max Line Pressure (psi)
6	99006	6.50	5.19	5.00	0.250	2800	155
8	99008	8.250	5.78	5.75	0.250	5000	170
10	99010	10.00	6.37	6.680	0.250	9000	195
12	99012	12.00	6.25	6.680	0.250	10500	160
15	99015	15.00	8.06	8.500	0.250	15000	160
18	99018	18.00	8.06	7.750	0.250	15000	105
24	99024	24.00	9.50	8.300	0.250	15000	50

